

BFM 1013

for generator sets

81 - 225 kW | 109 - 302 hp at 1500/1800 min⁻¹|rpm

EU Stage II / US EPA Tier 2

- Water-cooled 4 and 6-cylinder inline engines with turbocharging and charge air cooling
- The robust engine design allows worldwide operation even with high sulphur fuels.
- Easy, inexpensive installation due to minimum weight and small installation space.
- Best cold starting performance even under extreme conditions.

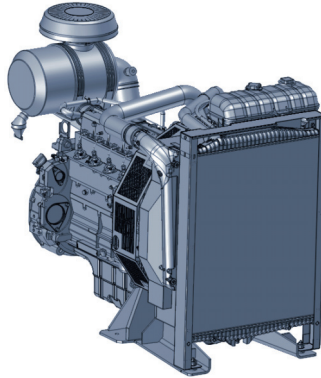

- Low noise emissions due to acoustically optimized components with very smooth running and high durability.
- Also available with an electronic motor regulator (EMR) to allow easy integration into the electronic device control and monitoring system.
- A very good load response ensures an immediate power supply.

Technical data

Engine type		BF4M1013EC	BF4M1013FC	BF6M1013EC	BF6M1013FC
No. of cylinders		4	4	6	6
Bore/stroke	mm in	108/130 4.25/5.12	108/130 4.25/5.12	108/130 4.25/5.12	108/130 4.25/5.12
Displacement	l cu in	4.8 291	4.8 291	7.2 436	7.2 436
Weight (incl. cooler and fan)	kg lb	560 1235	560 1235	770 1698	770 1698
Governing standard ¹⁾		G2	G2	G2	G2

50 Hz / 1500 min⁻¹

Power		BF4M1013EC	BF4M1013FC	BF6M1013EC	BF6M1013FC
Continuous Power (COP) ²⁾	kW hp	81.0/92.0 108.6/123.4	106.0 142.1	139.0 186.4	166.0 222.6
Prime Power (PRP) ³⁾	kW hp	85.0/97.0 114.0/130.1	117.0 156.9	146.0 195.8	183.0 245.4
Limited Time Power (LTP) ⁴⁾	kW hp	89.0/102.0 119.4/136.8	129.0 173.0	153.0 205.2	201.0 269.5
Fan power consumption	kW hp	5.9 7.9	5.0 6.7	7.2 9.7	7.2 9.7
Typical Generator Output COP ⁵⁾	kVA	85/97	116	152	183
Typical Generator Output PRP ⁵⁾	kVA	89/103	129	160	202
Typical Generator Output LTP ⁵⁾	kVA	94/108	143	168	223

60 Hz / 1800 min⁻¹

Power		BF4M1013EC	BF4M1013FC	BF6M1013EC	BF6M1013FC
Continuous Power (COP) ²⁾	kW hp	86.0/100.0 115.3/134.1	112.0 150.2	148.0 198.5	186.0 249.4
Prime Power (PRP) ³⁾	kW hp	90.0/105.0 120.7/140.8	124.0 166.3	155.0 207.9	204.0 273.6
Limited Time Power (LTP) ⁴⁾	kW hp	95.0/110.0 127.4/147.5	136.0 182.4	163.0 218.6	224.9 301.6
Fan power consumption	kW hp	10.2 13.7	8.7 11.7	8.7 11.7	12.4 16.6
Typical Generator Output COP ⁵⁾	kWe	68/81	93	128	160
Typical Generator Output PRP ⁵⁾	kWe	72/85	104	135	176
Typical Generator Output LTP ⁵⁾	kWe	76/90	115	142	196

1) According to ISO 8528-5.

2) Continuous Power: No time limitation, plus 10% additional power for governing purpose only.

3) Prime Power: Average power output ≤ 80%, no time limitation, plus 5% additional power for governing purpose only.

4) Limited Time Running Power: For up to 500 h/year, thereof a maximum of 300 h/year continuous running.

5) In consideration of a generator efficiency level of 90 - 92 % and a power factor of 0.8.

The data on this data sheet are for information purposes only and are not binding values. The data in the quotation is definitive.

The engine company.



50 Hz / 1500 min⁻¹

Fuel Consumption (PRP) ¹⁾		BF4M1013EC	BF4M1013FC	BF6M1013EC	BF6M1013FC
Fuel consumption 25% load	g/kWh lb/hph	246/237 0.40/0.39	221 0.36	234 0.38	222 0.36
Fuel consumption 50% load	g/kWh lb/hph	215/214 0.35/0.35	204 0.34	213 0.35	210 0.35
Fuel consumption 75% load	g/kWh lb/hph	210/211 0.35/0.35	203 0.33	209 0.34	208 0.34
Fuel consumption 100% load	g/kWh lb/hph	209/212 0.34/0.35	210 0.35	209 0.34	212 0.35
Heat balance & cooling system		BF4M1013EC	BF4M1013FC	BF6M1013EC	BF6M1013FC
Heat dissipation (engine radiator) ²⁾	kW hp	47.8/52.5 64.1/70.4	62.7 84.1	68.4 91.7	96.1 128.9
Heat dissipation (CAC) ²⁾	kW hp	9.9/13.1 13.3/17.6	23.7 31.8	24.0 32.2	42.0 56.3
Heat dissipation (convection)	kW hp	9.0/10.0 12.0/13.0	13.0 17.0	15.5 20.8	20.0 26.8
Cooling air flow	m ³ /h cfm	6100 3590	9000 5297	10800 6357	11520 6780
Inlet & exhaust data		BF4M1013EC	BF4M1013FC	BF6M1013EC	BF6M1013FC
max. intake depression	mbar psi	25 0.36	25 0.36	25 0.36	25 0.36
Combustion air volume	m ³ /h cfm	329/365 194/215	482 284	639 376	746 439
max. exhaust gas temperature	°C °F	540/560 1004/1040	530 986	535 995	530 986
Exhaust gas flow	m ³ /h cfm	951/1102 560/649	1389 818	1799 1059	2112 1243

60 Hz / 1800 min⁻¹

Fuel Consumption (PRP) ¹⁾		BF4M1013EC	BF4M1013FC	BF6M1013EC	BF6M1013FC
Fuel consumption 25% load	g/kWh lb/hph	270/251 0.44/0.41	235 0.39	253 0.42	231 0.38
Fuel consumption 50% load	g/kWh lb/hph	228/219 0.37/0.36	212 0.35	220 0.36	215 0.35
Fuel consumption 75% load	g/kWh lb/hph	217/213 0.36/0.35	211 0.35	214 0.35	214 0.35
Fuel consumption 100% load	g/kWh lb/hph	215/212 0.35/0.35	219 0.36	214 0.35	221 0.36
Heat balance & cooling system		BF4M1013EC	BF4M1013FC	BF6M1013EC	BF6M1013FC
Heat dissipation (engine radiator) ²⁾	kW hp	51.8/53.3 69.5/71.5	68.1 91.3	73.5 98.6	109.8 147.2
Heat dissipation (CAC) ²⁾	kW hp	17.3/21.0 23.2/28.2	30.7 41.2	33.7 45.2	50.9 68.3
Heat dissipation (convection)	kW hp	9.5/11.0 12.7/14.8	13.5 18.1	16.0 21.5	22.5 30.2
Cooling air flow	m ³ /h cfm	7600 4473	11520 6780	11500 6769	14760 8687
Inlet & exhaust data		BF4M1013EC	BF4M1013FC	BF6M1013EC	BF6M1013FC
max. intake depression	mbar psi	25 0.36	25 0.36	25 0.36	25 0.36
Combustion air volume	m ³ /h cfm	425/466 250/274	576 339	801 472	946 557
max. exhaust gas temperature	°C °F	490/520 914/968	530 986	480 896	530 986
Exhaust gas flow	m ³ /h cfm	1160/1316 683/775	1653 973	2097 1234	2666 1569

1) Refers to diesel with a density of 0.835 kg/dm³ at 15°C | 6.96 lb/US gallon at 60°F.

2) The heat quantities are valid for the dimensioning of the cooling system.

Dimensions

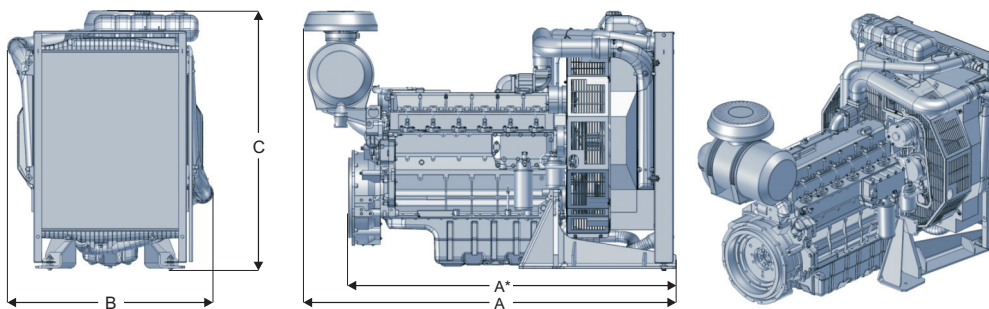

		A	A*	B	C
BF4M1013EC/FC	mm in	1479 58	1250 49	728 29	1151 45
BF6M1013EC	mm in	1870 74	1641 65	866 34	1239 49
BF6M1013FC	mm in	1923 76	1694 67	1003 39	1586 62

Note: The engine dimensions and weights vary depending on the scope of delivery.

For more information please contact the DEUTZ AG Köln or the responsible sales partner.

